

1.各部位的尺寸

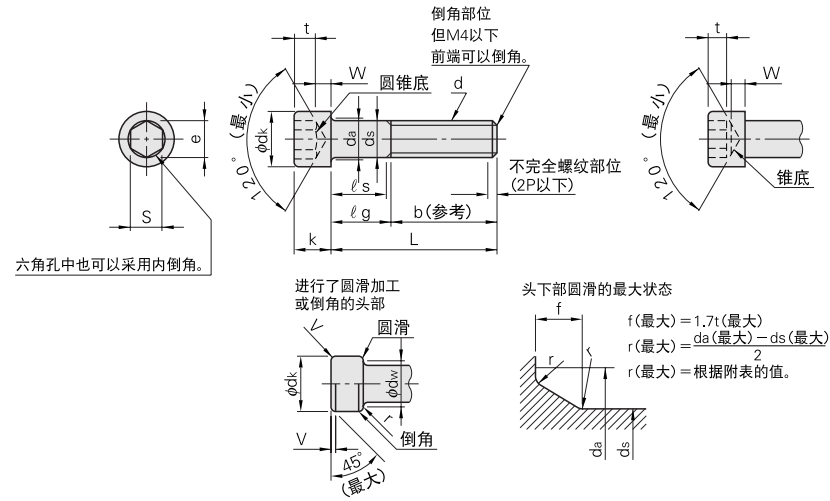

单位：mm

螺纹的公称直径(d) <sup>(15)</sup>	M3	M4	M5	M6	M8	M10	M12	(M14)	M16	(M18)	M20	(M22)	M24	(M27)	M30	
螺栓的螺距(P)	0.5	0.7	0.8	1	1.25	1.5	1.75	2	2	2.5	2.5	2.5	3	3	3.5	
b	参考	18	20	22	24	28	32	36	40	44	48	52	56	60	66	72
dk	最大(基准尺寸)*	5.5	7	8.5	10	13	16	18	21	24	27	30	33	36	40	45
	最大**	5.68	7.22	8.72	10.22	13.27	16.27	18.27	21.33	24.33	27.33	30.33	33.39	36.39	40.39	45.39
	最小	5.32	6.78	8.28	9.78	12.73	15.73	17.73	20.67	23.67	26.67	29.67	32.61	35.61	39.61	44.61
da	最大	3.6	4.7	5.7	6.8	9.2	11.2	13.7	15.7	17.7	20.2	22.4	24.4	30.4	33.4	
ds	最大(基准尺寸)	3	4	5	6	8	10	12	14	16	18	20	22	24	27	30
	最小	2.86	3.82	4.82	5.82	7.78	9.78	11.73	13.73	15.73	17.73	19.67	21.67	23.67	26.67	29.67
e	最小	2.87	3.44	4.58	5.72	6.86	9.15	11.43	13.72	16.00	16.00	19.44	19.44	21.73	25.15	
f	最大	0.51	0.60	0.60	0.68	1.02	1.02	1.45	1.45	1.45	1.87	2.04	2.04	2.04	2.89	2.89
k	最大(基准尺寸)	3	4	5	6	8	10	12	14	16	18	20	22	24	27	30
	最小	2.86	3.82	4.82	5.70	7.64	9.64	11.57	13.57	15.57	17.57	19.48	21.48	23.48	26.48	29.48
r	最小	0.1	0.2	0.2	0.25	0.4	0.4	0.6	0.6	0.6	0.6	0.8	0.8	0.8	1	1
s	公称(基准尺寸)	2.5	3	4	5	6	8	10	12	14	14	17	17	19	19	22
	最小	2.52	3.02	4.02	5.02	6.02	8.025	10.025	12.032	14.032	14.032	17.050	17.050	19.065	19.065	22.065
	最大 <sup>(14)</sup>	1栏	2.580	3.080	4.095	5.140	6.140	8.175	10.175	12.212	14.212	14.212	17.230	17.230	19.275	19.275
	2栏	2.560	3.080	4.095	5.095	6.095	8.115	10.115	12.142	14.142	14.142	17.230	17.230	19.275	19.275	22.275
t	最小	1.3	2	2.5	3	4	5	6	7	8	9	10	11	12	13.5	15.5
v	最大	0.3	0.4	0.5	0.6	0.8	1	1.2	1.4	1.6	1.8	2	2.2	2.4	2.7	3
d <sub>w</sub>	最小	5.07	6.53	8.03	9.38	12.33	15.33	17.23	20.17	23.17	25.87	28.87	31.81	34.81	38.61	43.61
w	最小	1.15	1.4	1.9	2.3	3.3	4	4.8	5.8	6.8	7.7	8.6	9.5	10.4	12.1	13.1

注<sup>(14)</sup> s(最大)的1栏适用于强度8.8及10.9及性状A2-50, A2-70的内容, 2栏适用于强度12.9的内容。但根据双方当事人之间协议, 强度12.9的内容也可以适用1栏。  
 螺纹的公称直径M20以上的s(最大)适用于所有的强度及性状内容。  
 注<sup>(15)</sup> 螺纹的公称直径中带括号的尽量不要使用。  
 备注 1. 头部的侧面带有平纹或花纹(参照JIS B 0951)滚花。此时, dk(最大)为该表中的带\*\*的数值。  
 此外, 需要没有滚花的货时订货人必须指定。但该dk(最大)为该表中带\*\*的数值。  
 2. 对于螺纹的公称直径建议使用的公称长度(ℓ)为粗线框内的内容。  
 如果ℓ比虚线位置短的为全螺纹, 杆部的不完全螺纹长度约为3P。  
 3. 名称长度(ℓ)比虚线位置长的话, ℓ<sub>g</sub>(最大)及ℓ<sub>s</sub>(最小)根据下式决定。  
 $\ell_g(\text{最大}) = \text{公称长度}(\ell) - b$   
 $\ell_s(\text{最小}) = \ell_g(\text{最大}) - 5P$

2.内六角螺栓的L和ℓs及ℓg

单位：mm

螺纹的公称直径(d)	M3	M4	M5	M6	M8	M10	M12	(M14)	M16	(M18)	M20	(M22)	M24	(M27)	M30																		
	ℓs min及ℓg max																																
公称长度	L		ℓs		ℓg		ℓs		ℓg		ℓs		ℓg		ℓs		ℓg																
	min	max	min	max	min	max	min	max	min	max	min	max	min	max	min	max	min	max															
5	4.76	5.24																															
6	5.76	6.24																															
8	7.71	8.29																															
10	9.71	10.29																															
12	11.65	12.35																															
16	15.65	16.35																															
20	19.58	20.42																															
25	24.58	25.42	4.5	7																													
30	29.58	30.42	9.5	12	6.5	10	4	8																									
35	34.5	35.5			11.5	15	9	13	6	11																							
40	39.5	40.5			16.5	20	14	18	11	16	5.75	12																					
45	44.5	45.5					19	23	16	21	10.75	17	5.5	13																			
50	49.5	50.5					24	28	21	26	15.75	22	10.5	18	5.25	14																	
55	54.5	55.6							26	31	20.75	27	15.5	23	10.75	19																	
60	59.4	60.6							31	36	25.75	32	20.5	28	15.25	24	10	20	6	16													
65	64.4	65.6									30.75	37	25.5	33	20.25	29	15	25	11	21	4.5	17											
70	69.4	70.6									35.75	42	30.5	38	25.25	34	20	30	16	26	9.5	22	5.5	18									
80	79.4	80.6									45.75	52	40.5	48	35.25	44	30	40	26	36	19.5	32	15.5	28	11.5	24							
90	89.3	90.7											50.5	58	45.25	54	40	50	36	46	29.5	42	25.5	38	21.5	34	15	30	9	24			
100	99.3	100.7											60.5	68	55.25	64	50	60	46	56	39.5	52	35.5	48	31.5	44	25	40	19	34	10.5	28	
110	109.3	110.7												66.25	74	60	70	56	66	49.5	62	45.5	58	41.5	54	35	50	29	44	20.5	38		
120	119.3	120.7												75.25	84	70	80	66	76	59.5	72	55.5	68	51.5	64	45	60	39	54	30.5	48		
130	129.2	130.8														80	90	76	86	69.5	82	65.5	78	61.5	74	55	70	49	64	40.5	58		
140	139.2	140.8														90	100	86	96	79.5	92	75.5	88	71.5	84	65	80	59	74	50.5	68		
150	149.2	150.8																96	106	89.5	102	85.5	98	81.5	94	75	90	69	84	60.5	78		
160	159.2	160.8																106	116	99.5	112	95.5	108	91.5	104	85	100	79	94	70.5	88		
180	179.2	180.8																		119.5	132	115.5	128	111.5	124	105	120	99	114	90.5	108		
200	199.05	200.95																			135.5	148	131.5	144	125	140	119	134	110.5	128			
220	219.05	220.95																												139	154	130.5	148
240	239.05	240.95																												159	174	150.5	168
260	258.95	261.05																												179	194	170.5	188
280	278.95	281.05																												199	214	190.5	208
300	298.95	301.05																												219	234	210.5	228

参考：内六角螺栓的沉头孔及螺栓孔的尺寸

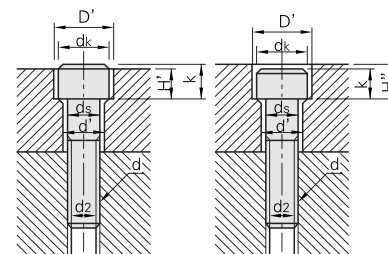

螺纹的公称直径(d)	M3	M4	M5	M6	M8	M10	M12	M14	M16	M18	M20	M22	M24	M27	M30
d <sub>s</sub>	3	4	5	6	8	10	12	14	16	18	20	22	24	27	30
d'	3.4	4.5	5.5	6.6	9	11	14	16	18	20	22	24	26	30	33
dk	5.5	7	8.5	10	13	16	18	21	24	27	30	33	36	40	45
D'	6.5	8	9.5	11	14	17.5	20	23	26	29	32	35	39	43	48
K	3	4	5	6	8	10	12	14	16	18	20	22	24	27	30
H'	2.7	3.6	4.6	5.5	7.4	9.2	11	12.8	14.5	16.5	18.5	20.5	22.5	25	28
H''	3.3	4.4	5.4	6.5	8.6	10.8	13	15.2	17.5	19.5	21.5	23.5	25.5	29	32
d <sub>2</sub>	2.6	3.4	4.3	5.1	6.9	8.6	10.4	12.2	14.2	15.7	17.7	19.7	21.2	24.2	26.7

单位：mm

技术参数